

.050 [1.27]/.100 [2.54] PITCH

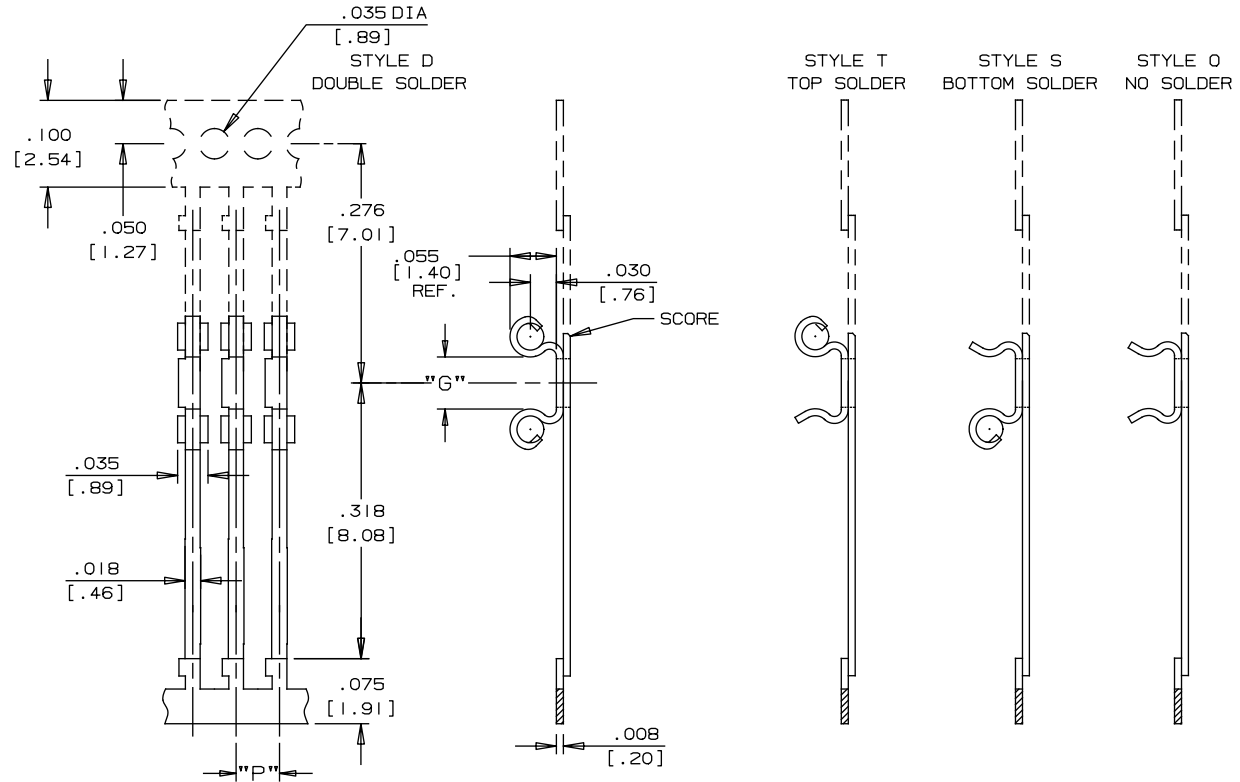

www.interplexnas.de | www.interplex.com/NAS

SELECT SPECIFIC OPTIONS TO DETERMINE ORDERING CODE:

TYPE	PITCH (P)	DRWG. NO.	SOLDER LOCATION	GAP (G)	SOLDER TYPE	SOLDER STOP	STAND OFF (SO)	MATERIAL/ PLATING	STANDARD ORIENTATION
A = DIP	A = .100[2.54] C = .050[1.27]	07AA	D = Double T = Top S = Bottom O = No Solder	22 = .022[0.558] 36 = .036[0.914] 56 = .056[1.42]	See Chart on Page 9	O = No Stop S = Stop	O = None	E = Phosphor Bronze Pre-Plated 100% Sn K = Phosphor Bronze Post-Plated 100% Sn C = Phosphor Bronze Pre-Plated Sn60/Pb40 H = Phosphor Bronze Post-Plated Sn60/Pb40	D = WINDING (DD)

CODE:

--	--	--	--	--	--	--	--	--	--