

Rev	Description	Date	By
A	INITIAL RELEASE	07/24/08	JSC

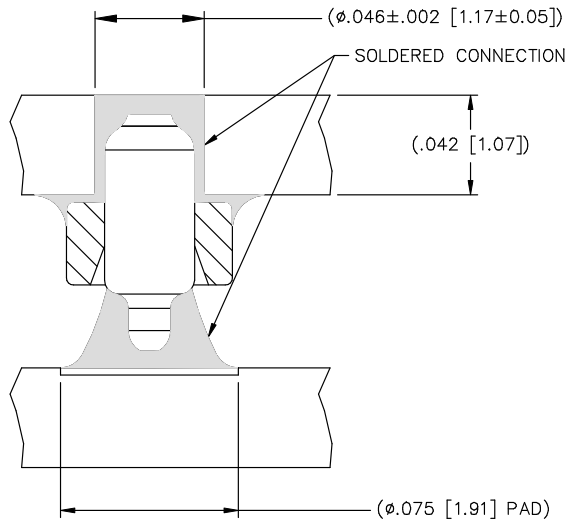

PRODUCT APPLICATION VIEW

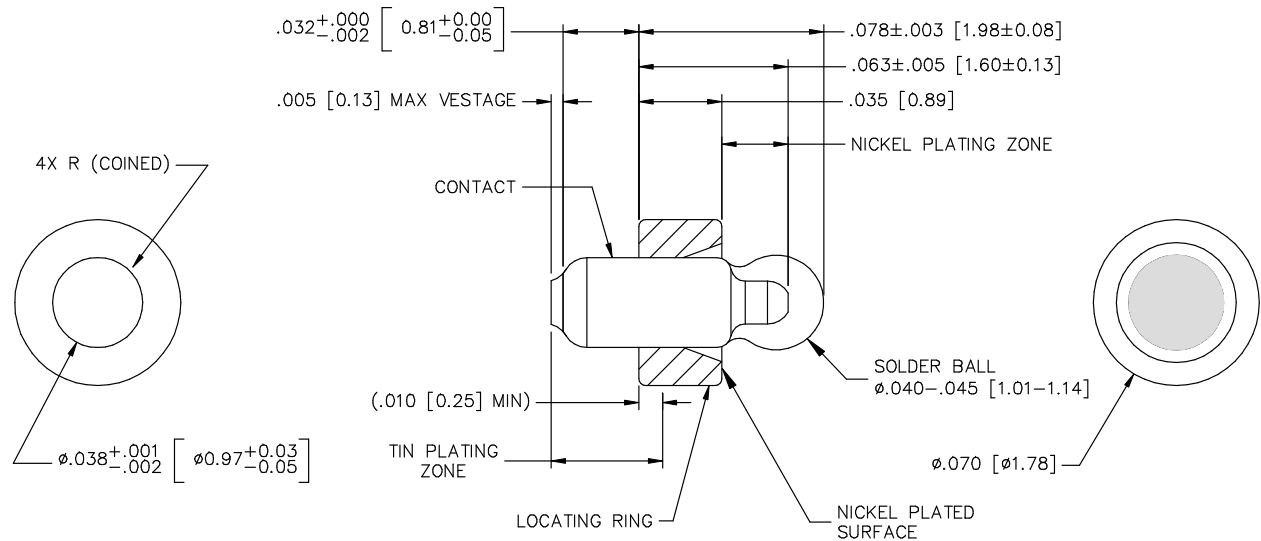



NOTES: UNLESS OTHERWISE SPECIFIED

- 1 INTERPRET THIS DRAWING IN ACCORDANCE WITH ASME Y14.5M 1994
- 2 FOR ADDITIONAL VARIATIONS CONTACT TEKA'S CUSTOMER SERVICE DEPARTMENT
- 3 PARTS TO TAPE & REEL PACKAGED PER EIA SPECIFICATION.
QTY: 1800; 13 INCH REEL; .31 [8.0] SPACING

MATERIALS:

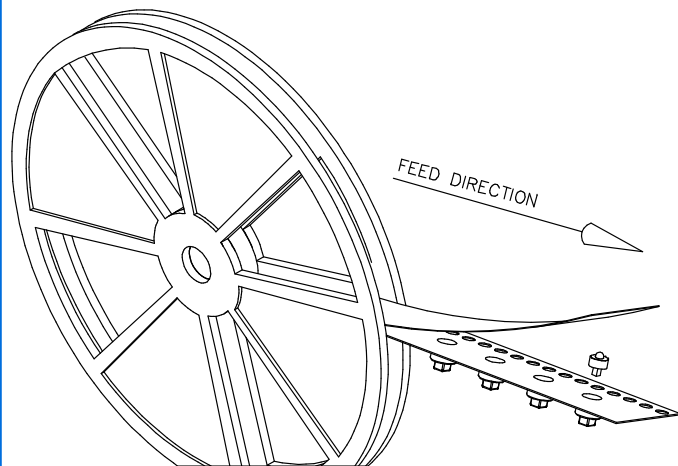
- CONTACT: CDA 11000 (COPPER ALLOY)
 LOCATING RING: CDA 26000
 SOLDER BALL: SAC 305
 CONTACT FINISH: SELECTIVELY PLATED 200 MICROINCHES LOW STRESS TIN OVER 100 MICROINCHES MIN NICKEL
 LOCATOR FINISH: SELECTIVELY PLATED 200 MICROINCHES LOW STRESS TIN OVER 100 MICROINCHES MIN NICKEL



Unless otherwise specified: All dimensions are: Inches [mm] -Tolerances- No of places IN [mm] one ±.1 ±2,54 two ±.02 ±0,5 three ±.003 ±0,08 Angular ±2°	Drawn by: J CACHINA	Date: 07/24/08	 AN INTERPLEX INDUSTRIES CO. 100 PIONEER AVE. WARWICK, R.I. 02888 TEL: (401) 785-4110 FAX: (401) 781-5730 E-MAIL: sales@tekas.com
	Checked by: JSC	Date: 07/24/08	
	Ref No: X20816	Scale: 20:1	Sheet 1 of 1