

Rev	Description	Date	By
A	INITIAL RELEASE	02/05/07	JSC

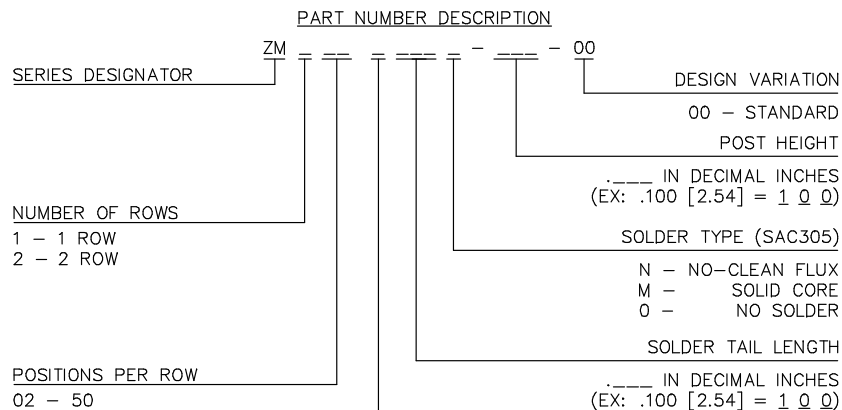

CONTACT FINISH DESIGNATION $\triangleleft 5$		
DESIGNATION	MATING ZONE	SOLDER TAIL
S	GOLD - FLASH	GOLD - FLASH
Z	GOLD - 10 MICROINCHES	GOLD - 10 MICROINCHES
C	GOLD - FLASH	PURE TIN - 100 MICROINCHES
B	GOLD - 10 MICROINCHES	PURE TIN - 100 MICROINCHES
H	GOLD - 30 MICROINCHES MIN	PURE TIN - 100 MICROINCHES
O	PURE TIN - 100 MICROINCHES	PURE TIN - 100 MICROINCHES

NOTES: UNLESS OTHERWISE SPECIFIED

- 1 INTERPRET THIS DRAWING IN ACCORDANCE WITH ASME Y14.5M - 1994
- 2 FOR OTHER SIZES, FINISHES, SOLDER VOLUMES OR ADDITIONAL DATA CONSULT TEKA CUSTOMER SERVICE DEPARTMENT
- 3 CONNECTOR SOLDER VOLUME BASED ON APPLICATION TO A .062±.007 [1.58±0.18] THICK PRINTED CIRCUIT BOARD
- 4 CONTACT MATING ZONE LENGTH (GOLD AREA) FOR SELECTIVE FINISHES IS 3.00 [.118]
- 5 ALL TIN FINISHES ARE LOW STRESS / WHISKER MITIGATING MATERIALS:

HOUSING: HIGH TEMPERATURE THERMOPLASTIC, UL RATED 94-V0

CONTACT: COPPER ALLOY

SOLDER: SEE PART NUMBER DESCRIPTION

CONTACT FINISH: (SEE PART NUMBER DESCRIPTION)

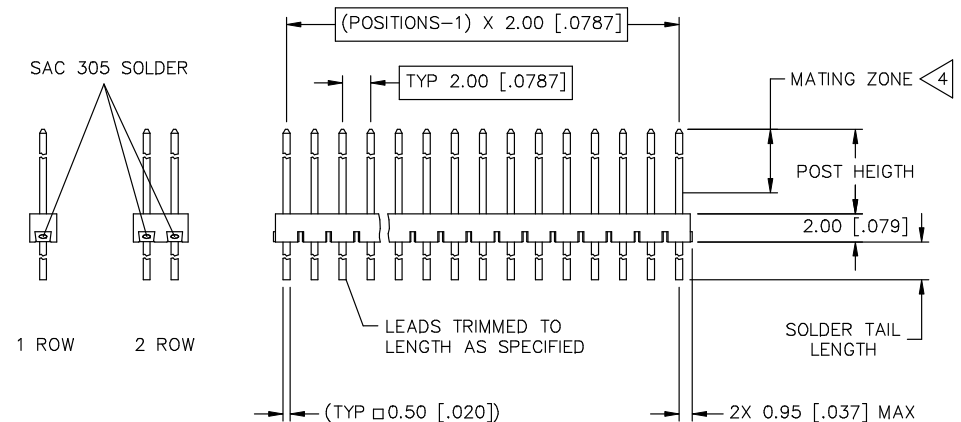
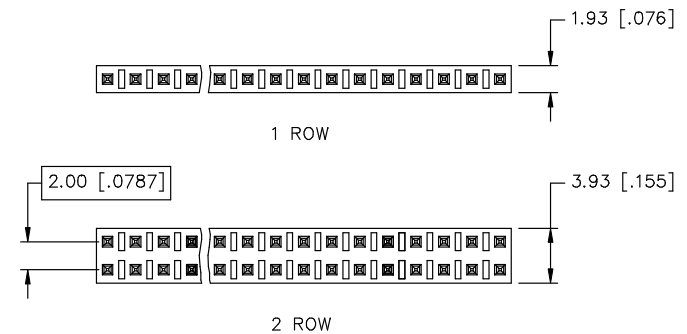
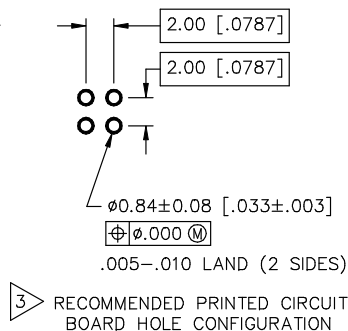

Unless otherwise specified: All dimensions are: mm [Inches]	Drawn by: J CACHINA	Date: 02/05/07	 AN INTERPLEX INDUSTRIES CO. 100 PIONEER AVE. WARWICK, R.I. 02888 TEL: (401) 785-4110 FAX: (401) 781-5730 E-MAIL: sales@teka.com
-Tolerances-	Checked by: JSC	Date: 02/05/07	
No of places	Title: SB HEADERR (MOD) - 2.00 MM PITCH (ROHS COMPLIANT)		Part No: ZM_____ - ____-00
one $\pm 0,5 \pm 0,20$	Ref No: S20702		Scale: 3:1
two $\pm 0,25 \pm 0,10$			Sheet 1 of 1
three $\pm 0,13 \pm 0,05$			
Angular $\pm 2^\circ$			